

1006 PT Truck- Bruks Concept

Product data sheet

Transport height (A) [mm]	4000
Length (B) [mm]	8000
Wheel base (C) [mm]	3900
Transport width (D)	2500
Width infeed (E) [mm]	1200
Width infeed table (F) [mm]	2350
Weigth complete unit approx [ton]	26

Diameter chipper drum[mm]	1000
Infeed opening W xH [mm]	1200 x 750
Adjustable chip length [mm]	10- 45
Max diameter, softwood[mm]	600
Max diameter, hardwood [mm]	500
Capacity [m3/h]	150-250
Suitable power truck (hp)	730-750
Suitable crane, lifting moment & reach	100kNm-10m

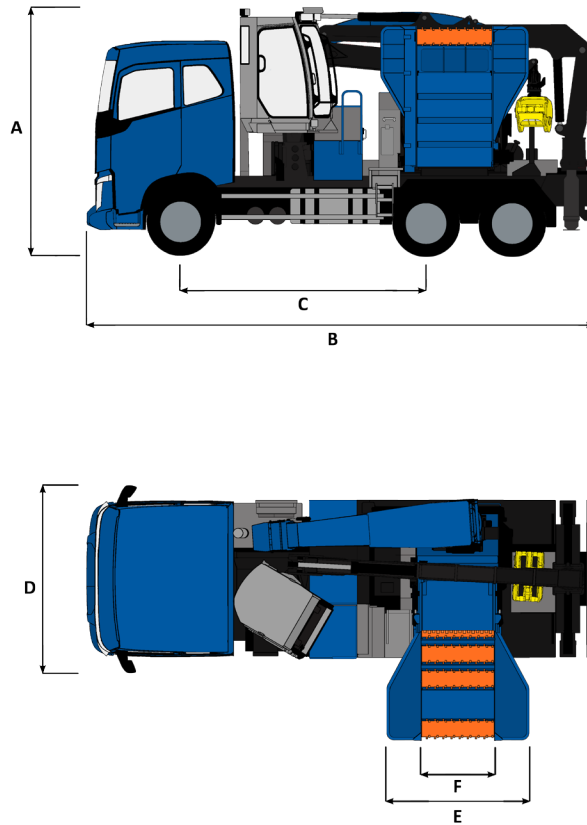

Alternative equipment

To equip your machine to optimum performance, BRUKS offers different choices: 5-roll infeed table, Different knife sets. Various sets of sleever breakers. Dual chip deflector.

Optional equipment

The optional / additional equipment you can choose: Fire extinguishing system. Dual pedals. Monitor for reversing camera. Tool box. LED work lights. Air intake pre-cleaner. Steel fenders. Filling equipment for hydraulic oil. Water heating for hyd.oil. Coupling -VBG. Sand spreader Slirej 60L or 90L. Extra support legs "A-model. Extra support legs "straigh model". Radio remote control. Dialing modem for troubleshooting support. Wood cracker. Different options at Crane & Grapple.